



WINNEBAGO TRAVATO

FREQUENTLY ASKED QUESTIONS

SuperSprings® International, Inc.
505 Maple Avenue | Carpinteria, CA 93013
supersprings.com

WELCOME!

This document highlights frequently asked questions regarding SumoSprings for the front and rear of the Winnebago Travato. Travato owners authored and submitted questions to SuperSprings. All of the answers provided here are authored by SuperSprings – more information is available on supersprings.com

TABLE OF CONTENTS

INTRODUCTION BY TRAVATO OWNERS	3
Real people, real comments, real experiences	
THE BASICS	4
What are SumoSprings?	
Do I really need SumoSprings?	
What's wrong with my "stock" suspension?	
Are SumoSprings compatible with my original equipment?	
What benefits can I expect from SumoSprings?	
How long will SumoSprings last?	
THE COLORS	5
What is the difference between SumoSprings' colors?	
What color SumoSprings are best for my Travato?	
When should I specify what color SumoSprings I want?	
FRONT? REAR? BOTH?	6
What are Coil SumoSprings?	
Do I really need Coil SumoSprings?	
What benefits can I expect from Coil SumoSprings?	
Can I use only SumoSprings Rear, without Coil SumoSprings?	
PURCHASING	7
Where can I purchase SumoSprings?	
What is the difference between purchasing direct from SuperSprings or through a Dealer/Installer?	
Is there a Travato Owners discount?	
How do I use the coupon code?	
INSTALLATION	8
How are SumoSprings Rear kits installed?	
Can I install SumoSprings by myself?	
How are Coil SumoSprings installed?	
Can I install Coil SumoSprings myself?	
Are any special tools required to install SumoSprings or Coil SumoSprings?	
Can I install SumoSprings on a used Travato?	
Where can I get SumoSprings installed by an installer?	
What should I pay for SumoSprings installation?	
My shop has never worked with SumoSprings before, and are quoting \$250 an hour for labor. Is that excessive? Can SuperSprings help them with Technical Support?	
WARRANTY	9
Do SumoSprings come with a warranty?	
Are self-installed SumoSprings covered under the warranty, or do they need to be professionally installed?	
Will installing SumoSprings void my Travato's warranties?	

TRAVATO

SumoSprings®

FLIP THROUGH THIS BOOKLET TO LEARN ABOUT HOW SUMOSPRINGS MAKE A GREAT COACH BETTER!

INTRODUCTION BY “TRAVATO OWNERS”

Real people, real comments, real experiences

Before we let SuperSprings answer all of our questions and share how great their products are, here are some unsolicited comments praising SumoSprings and highlighting the reasons you may be considering SumoSprings for your Travato. If you are a member of the “Travato Owners and Wannabees” Facebook Group Page, use the “Search this group” feature to read what other group members have to say about their SumoSprings experience.



HERE'S WHAT TRAVATO OWNERS HAD TO SAY

I can say that the ride is very stable, predictable and seems smoother. I notice no side-to-side 'swash' when on uneven roadways or entering parking lot incline / decline ramps. Definitely worth it in my humble opinion.

Don't they make an amazing difference? We have the yellows and have been very impressed!

First wow moment was pulling out onto the highway through a bump/drop in their driveway. This is definitely a good thing!

I have one word for all of you T owners and wannabees and it is 'smooth' what the ride feels like with the SumoSprings installed!



RV Photos: Courtesy of Winnebago Industries, Inc.



Yay! We love our SumoSprings, the best mod we've done. Those of us who live east of the Mississippi, with roads notoriously full of pot holes, really appreciate them!

Installed SuperSprings' SumoSprings suspension modifications front & rear, and it now rides & handles like a Travato SE, sports edition. A lot of bang for the buck IMHO.

Installed SuperSprings' SumoSprings suspension modifications front & rear, and it now rides & handles like a Travato SE, sports edition. A lot of bang for the buck IMHO.

Sure feels like the SumoSprings make a difference in handling!

Q: Does it make the steering feel more stable?
Around corners? Yes. Can take them at higher speeds too.

Yeah, Sally is more like a sports car now!

THE BASICS

For more than 20 years, SuperSprings has designed, developed, patented, and introduced numerous innovative suspension solutions. All SuperSprings products are proudly manufactured in the U.S.A., including SumoSprings, the world's first and only airless airbag.

What are SumoSprings?

SumoSprings are a patented suspension enhancement product designed to increase ride comfort, stabilize sway, improve driver control, and level sag. SumoSprings, like airbags, are a type of air spring. The main difference between an airbag and SumoSprings is how the air is captured/controlled. With a traditional air bag, a compressor with hoses and valves are used to inflate the "balloon." This requires maintenance so the air bag does not crack and/or leak and accessories such as a compressor to maintain and adjust the air pressure. The air within SumoSprings is captured in millions of air pockets inside of the proprietary micro-cellular urethane material. We have drilled a hole through SumoSprings and they still work. The Winnebago Travato uses a SumoSprings Rear Solo kit; solo meaning it attaches on one side (the frame). SumoSprings replace the Travato's original bump stop, turning a preventative suspension accessory, the bump stop, into an active part of your suspension, an air spring, SumoSprings!

Do I really need SumoSprings?

No. You do not need SumoSprings. Your Travato does not need SumoSprings to hit the open road. You want SumoSprings if you want to enhance your suspension and improve your ride quality. Here is an analogy. You buy an iPad to take with you on your Class B adventures. The iPad works great just the way it is out of the box. You buy some enhancements; not because the iPad is inadequate, but because the enhancements improve the iPad based on your wants and needs: a case, because you may take it outdoors while camping; a screen protector, because you are clumsy and tend to drop things; a Bluetooth speaker, because you like to rock out; you download an app, because you like to play games. It is not that the iPad "needed" these improvements/enhancements; the improvements made the iPad a better product. The same is true for SumoSprings. Adding SumoSprings compliments and improves your Class B van.

What's wrong with my "stock" suspension?

There's nothing wrong with your stock suspension. Winnebago makes great coaches; but, great can always get better, right? Installing SumoSprings takes your suspension to the next level. SumoSprings are engineered to reduce sway, increase stability and absorb shocks/bumps on rough roads. Quick to install with just a few tools, SumoSprings make a great coach better.

Are SumoSprings compatible with my original equipment?

Yes. Travato SumoSprings were developed specifically for the RAM ProMaster 3500. Our engineers installed and tested



TOP 5 BENEFITS ▶ SUMOSPRINGS



SHOCK ABSORPTION

Superior damping properties



SWAY CONTROL

Reduces sway and increases stability



MAINTENANCE-FREE

Fit it and forget it



LEAK-PROOF

No leaks, ever



LOAD SUPPORT

Progressive spring rate helps level varying loads

SumoSprings on a Winnebago Travato. These SumoSprings are intended to work in conjunction with your original equipment. To give credit where it is due, Travato Owners helped SuperSprings' engineers redesign the original kit, making it even easier to install specifically for Travato owners.

What benefits can I expect from SumoSprings?

SumoSprings will improve your ride. SumoSprings reduce sway, absorb and dissipate vibrations, and provide the driver with more control on uneven terrain and/or harsh conditions. SumoSprings increase driver, passenger and cargo safety. They reduce the amount of wear and tear on original components, reducing maintenance costs and overall cost of ownership.

How long will SumoSprings last?

SumoSprings come with a [Limited Lifetime Warranty](#). Read more about the details on page 10. In short, we stand behind our SumoSprings. If they wear out, and you are driving the same Travato, we will replace them. This happens less than 0.0001% of the time – literally.

THE COLORS

The different SumoSprings colors identify their density. SumoSprings come in three different densities: -40, -47, and -54. Blue SumoSprings are -40, black SumoSprings are -47, and yellow SumoSprings are -54. Blue -40 density captures more air in the millions of micro-cellular bubbles, creating an air spring suitable for light and medium duty applications. Black -47 density balances the amount of urethane and air bubbles to create an air spring suitable for light, medium, and heavy-duty applications. Yellow -54 density traps a smaller amount of air in the air spaces creating a firmer and more dense air spring suitable for medium and heavy-duty applications.

SSR-313-40
■ Blue -40
 1000 (lb) Capacity
 at 50% Compression

SSR-313-47
■ Black -47
 1500 (lb) Capacity
 at 50% Compression

SSR-313-54
■ Yellow -54
 2800 (lb) Capacity
 at 50% Compression



LIGHT & MEDIUM DUTY
 PROMASTER 1500-2500

LIGHT, MEDIUM, & HEAVY DUTY
 PROMASTER 2500-3500

MEDIUM & HEAVY DUTY
 PROMASTER 3500

What is the difference between SumoSprings' colors?

SumoSprings come in various densities, also referred to as durometer, grade, or light/medium/heavy duty. The SumoSprings for the Travato come in Black (-47) or Yellow (-54). We rate SumoSprings by how many pounds of pressure it takes to compress them down to half their body height. The Black (-47) SumoSprings are rated at 1500 lb, and the Yellow (-54) SumoSprings are rated at 2800 lb. We also have Blue -40 SumoSprings rated at 1000 lb. Those would be a bit soft on a Travato and are more appropriate for the ProMaster 1500 series vans.

What color SumoSprings are best for my Travato?

The consensus, simply by sales numbers, is the -54, which has a higher density than the -47. If you are considering adding any weight to the rear, we 100% suggest the -54. If you do not plan on adding any weight to the rear, the -47 or -54 work great and it is a personal preference. If you like handling a little tighter, like a German car, go with the -54. If you like feeling a little more movement in your handling, go with the -47. Both reduce sway and absorb road shock, just their resistance under greater loads and weight transfer differs.

When should I specify what color SumoSprings I want?

The density is included in the part number nomenclature. The part numbers for SumoSprings Rear for Travatos are SSR-313-47 or SSR-313-54. SSR stands for SumoSprings Rear. The first three, in 313, stands for Fiat Chrysler Automobiles (FCA), including Dodge and RAM. The 47 stands for the black density and the 54 stands for the yellow density.

FRONT? REAR? BOTH?

Installing SumoSprings on all four corners is highly recommended. Suspension is holistic; both front and rear ends working together. Front suspension is just as critical as rear suspension. Rear SumoSprings standalone make a great difference (specifically for Travatos), but additional improvement and an increase in safety is achieved by stabilizing the front coil springs. SuperSprings manufactures Coil SumoSprings for the Travato's front suspension, designed to enhance the coil spring. Coil SumoSprings do not interfere with or change anything mechanically with steering or other critical components.

What are Coil SumoSprings?

Coil SumoSprings improve the load leveling ability of original equipment front and rear coil springs. They are manufactured from the same micro-cellular urethane as SumoSprings. The material's progressive spring rate creates a cushion effect, enhancing capacity and ride comfort. The enhanced capacity and load leveling ability helps reduce sway in the Travato and reduces porpoising.

Do I really need Coil SumoSprings?

No. You do not need Coil SumoSprings. Refer to the answer under "Do I need SumoSprings?" The word "need" is a silly word in the English language. What "need" really means in English is, "a want to fulfill another want." You do not need air or water; you want air and water because it fulfills another want you have, the want to live. You want SumoSprings, and Coil SumoSprings, because you want improved ride comfort and reduced sway. Your Travato does not need them, but in order to fulfill your want for improved ride quality, you do need/want SumoSprings and Coil SumoSprings!

What benefits can I expect from Coil SumoSprings?

The benefits of Coil SumoSprings are tantamount to the benefits of SumoSprings. They are made from the identical proprietary micro-cellular urethane material as SumoSprings. Coil SumoSprings will compliment SumoSprings Rear. The two will work together to reduce sway, increase driver control, and improve ride comfort.

Can I use only SumoSprings Rear, without Coil SumoSprings?

You could – absolutely – yes. However, should you? SumoSprings Rear, especially on the Travato, make such a substantial improvement, the front suspension is often overlooked. That said, we highly recommend front suspension enhancements when someone has enhanced the rear suspension. Suspension is holistic, with both front and rear ends working together. I like this analogy:

Imagine a brick; a plain old red brick. Place that brick on ball-point pen springs, the little springs inside of a "click" pen. The brick is unsteady, right? It sways! Now, replace two of those springs with solid wood or steel, something stiff. The brick still sways! Now, replace all the springs with steel or wood, and the brick is fully supported.

Obviously, we are supporting your Travato's suspension, not replacing it or making it stiffer, but the holistic analogy is true. If you have a reason for enhancing your suspension – if you have made a want into a need – improving only the rear is shortchanging the overall improvement to your Travato.



COMPLETE SUSPENSION SOLUTION



2019 Travato
Built on
Ram ProMaster® 3500 chassis



Front | CSS-1195
Coil capacity increased
by 15% to 30%



Rear | SSR-313-54
2800 (lb) Capacity at
50% Compression

PURCHASING

Where can I purchase SumoSprings?

As a manufacturer, SuperSprings is very proud to support the many dealer, retail, warehouse, and eTailer locations selling our products. We also strive to honor customers' requests to purchase confidently and directly online from the manufacturer. For this reason, we have created the Official SuperSprings Online Shop, www.supersprings.com/shop.

What is the difference between purchasing direct from SuperSprings or through a Dealer/Installer?

Products listed in the Official SuperSprings Online Shop are sold and shipped directly by SuperSprings. When purchasing through a reseller, especially an eTailer (eCommerce website), evaluate the seller's validity. We have many great partners who sell our products online. We will even "drop ship" for those partners; meaning, you place an order through

their website, but they do not stock it – we do – and, we ship it for them to you. There are also unauthorized third-party resellers who we do not support. If the price seems low in comparison to everyone else, it is likely an unauthorized reseller who is not abiding by our policies, obtaining our products illicitly, selling used products, or swindling you. If you have any questions on the legitimacy of a reseller, please contact us and we will let you know if they are an authorized reseller or not. We have a relationship with all of our partners and resellers, and are happy to share those contacts with you.

Is there a Travato Owners discount?

There are many Facebook Groups and social communities. The Travato community is unique in that the members are engaged with other members AND manufacturers (Winnebago and SuperSprings included). There are friendships, meet-ups, mentors, and more. Thanks

to the questions asked in your group and members' willingness to communicate directly with us, SuperSprings has had the privilege of meeting numerous group members. More, thanks to the group members, we were able to improve our product, making the installation easier, specifically for Travato owners. As a small token of our appreciation for the communication and relationship we have had with the community, SuperSprings has created a 10%-Off coupon code.

How do I use the coupon code?

Visit www.supersprings.com/shop, add SumoSprings Rear and Coil SumoSprings to your cart. At checkout, enter coupon code TRAVATO. You will see the 10% discount applied to your total. Remember to select "Free Shipping," for free UPS ground shipping to the contiguous U.S.A. for all orders under 70 lb.

Find local authorized resellers
or buy directly from the factory
at Supersprings.com



TRAVATO OWNERS USE COUPON CODE "TRAVATO" TO SAVE 10% AT CHECKOUT

INSTALLATION

How are SumoSprings Rear kits installed?

First, you need to get the wheels off the ground by lifting your Travato. We suggest using safety jack stands rated for your Travato. Once lifted, some people prefer to remove the rear wheels, but it is not necessary, they just need to be off the ground. The original equipment bump stop is the maroon/red/brown colored piece of rubber directly over the center of your rear leaf springs. Use either large Channellock pliers, a spanner, oil filter, or similar type wrench to unbolt and turn the bump stop counter clockwise. The instructions will give the option to use one or both spacers; for Travatos, we recommend using both spacers, as assembled in the box. The SumoSprings ship ready to go! Apply a little Loctite (included) to the bolt of the preassembled SumoSprings, then twist into place. Tighten by hand, as much as you can, and that is it!

Can I install SumoSprings by myself?

If you have changed a tire or used a wrench, you more than likely have the mental know-how to install SumoSprings on your own. The installation is as simple as one bolt. No brackets, no drilling, no fancy tools required... just one bolt. On newer Travatos, owners have reported the original bump stop twists off easily using Channellock pliers. On Travatos more than a couple years old, some owners have had difficulty removing the original bump stop. You may need to use a socket wrench to loosen the bolt.

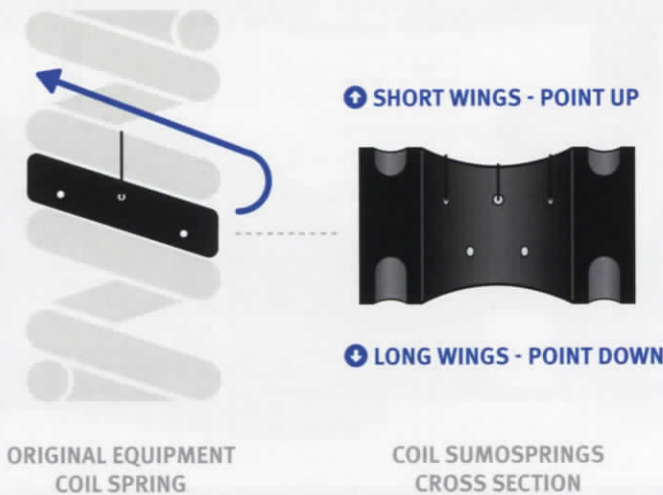
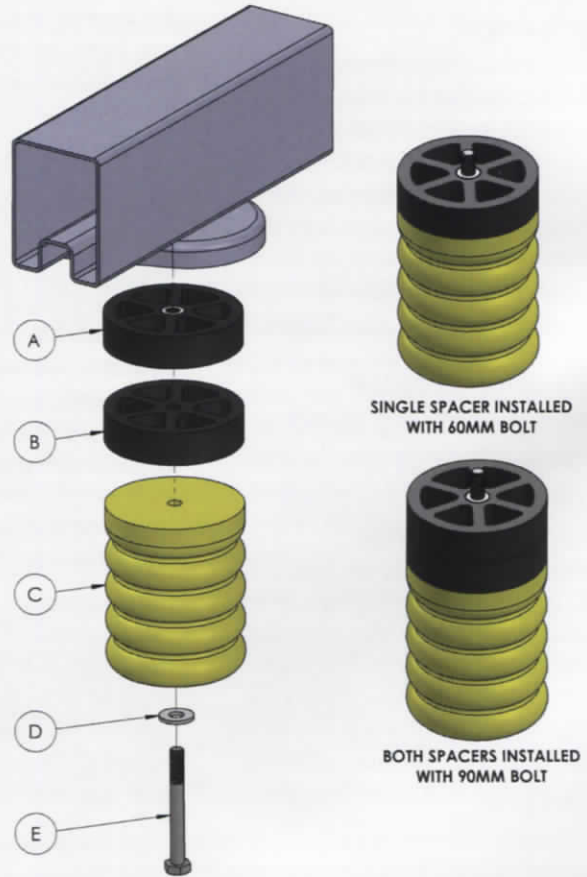

How are Coil SumoSprings installed?

Coil SumoSprings are installed by raising the vehicle so the front coils are unloaded (i.e. wheels are off the ground). We suggest removing the wheel for Travato installations. The top attachment point of the coil on the Travato is inside of a housing. This means the middle coil, where you want to install the Coil SumoSprings, is just barely exposed below the housing. The Coil SumoSprings slide into this middle turn in the coil spring. You start by getting the "wings" of the Coil SumoSprings in position, and then you push and slide the Coil SumoSprings into the turn. The longer wings of the Coil SumoSprings point down, and the shorter wings point up. Once in, there is about a three to four inch gap from end to end of the Coil SumoSprings. The positioning of this



INSTALL WITH THE LARGER WINGS POINTED DOWN



COIL SUMOSPRINGS FULLY INSTALLED

gap has no effect on the Coil SumoSprings performance; it can face inboard (towards the other side of the Travato), or outboard (towards you, the installer). Once in place, use the included zip ties to secure the Coil SumoSprings to the coil spring. Attach the zip ties to only the top holes (the short wing side). This is to prevent the Coil SumoSprings from coming out of the turn in the coil if you experienced extreme vertical travel.

Can I install Coil SumoSprings myself?

If you are comfortable jacking up your Travato and removing the wheel, yes! The installation requires no tools and no prior experience.

Are any special tools required to install SumoSprings or Coil SumoSprings?

You do not need any special tools to install SumoSprings or Coil SumoSprings. To remove the factory bump stop during the SumoSprings Rear installation, you will need a wrench large enough to grab the original Travato bump stop. Most commonly, a large pair of Channellock pliers will do the trick.

Can I install SumoSprings on a used Travato?

Yes, we encourage you to! SumoSprings will support the leaf spring assembly and coil spring, extending the life of the original equipment, and reducing stress on other components. Installing SumoSprings will lower your overall cost of ownership! The bump stop may be more difficult to remove depending on how much weathering has taken place.

Where can I get SumoSprings installed by an installer?

If you are looking for a reputable installation location, the many Travato owners on your Facebook group are our first suggestion. Second, you can use the Locate Dealer tool at www.supersprings.com/learn-more/locate-dealer/ to search nearby, by city, zip code, or address.

What should I pay for SumoSprings installation?

We would again suggest consulting your Facebook group. Installation rates across the country vary drastically.

In terms of hours:

- ▶ Front - 30 minutes to 2 hours.
- ▶ Rear - 30 minutes to 2 hours.

My shop has never worked with SumoSprings before, and are quoting \$250 an hour for labor. Is that excessive? Can SuperSprings help them with Technical Support?

Installation rates vary too much by location to authoritatively say what is and what is not excessive. \$250 an hour is astronomically high when compared to other known hourly rates. Your Facebook group members will have real world quotes I am sure they will share with you. If an installer is unfamiliar with our products, they can call our Technical Support team at +1 (866) 898-0720 or e-mail tech@supersprings.com.



WARRANTY



ALL PRODUCTS INCLUDE

LIMITED LIFETIME WARRANTY

Do SumoSprings come with a warranty?

Yes. SumoSprings come with a limited lifetime warranty. The lifetime warranty is limited to the original vehicle your SumoSprings were installed on. Other limitations include proper installation, avoiding abusive environments like racing, and other details you can find here: supersprings.com/warranty.

Are self-installed SumoSprings covered under the warranty, or do they need to be professionally installed?

As long as SumoSprings were installed properly – meaning, you did not weld them, duct tape was not involved, and Kraggle from The Lego Movie was avoided – self-installed and dealer installed SumoSprings are all covered under the same limited lifetime warranty. Proper installation is one of those limitations detailed in the warranty document. For you SumoSprings' veterans that may have received a 3-year warranty card, before we implemented a limited lifetime

warranty, the current warranty covers your SumoSprings, even if they are older than three years!

Will installing SumoSprings void my Travato's warranties?

Unfortunately, I cannot answer this question directly since we have not issued you the warranty, nor do we know the specifics of your warranty. I can share what is known as the "Magnuson-Moss Warranty Act," and point you in a good direction to better understand auto warranties in general.

Here is what the Federal Trade Commission has to say on their website*:

Will using 'aftermarket' or recycled parts void my warranty?

No. An 'aftermarket' part is a part made by a company other than the vehicle manufacturer or the original equipment manufacturer. A 'recycled' part is a part that was made for and installed in a new vehicle by the manufacturer or the original equipment manufacturer, and later removed from the vehicle and made available for resale or reuse. Simply using an aftermarket or recycled



part does not void your warranty. The Magnuson-Moss Warranty Act makes it illegal for companies to void your warranty or deny coverage under the warranty simply because you used an aftermarket or recycled part. The manufacturer or dealer can, however, require consumers to use select parts if those parts are provided to consumers free of charge under the warranty. Still, if it turns out that the aftermarket or recycled part was itself defective or wasn't installed correctly, and it causes damage to another part that is covered under the warranty, the manufacturer or dealer has the right to deny coverage for that part and charge you for any repairs. The FTC says the manufacturer or dealer must show that the aftermarket or recycled part caused the need for repairs before denying warranty coverage.



ALL PRODUCTS INCLUDE

30-DAY MONEY BACK GUARANTEE

* FTC link: <https://www.consumer.ftc.gov/articles/0138-auto-warranties-routine-maintenance>

NOTES



RV Photos: Courtesy of Winnebago Industries, Inc.



SumoSprings®



PROUDLY MADE IN AMERICA

ALL OF OUR QUALITY PRODUCTS ARE MANUFACTURED AND ASSEMBLED IN THE USA

SuperSprings® International, Inc.
505 Maple Avenue | Carpinteria, CA 93013
supersprings.com

RV Photos: Courtesy of Winnebago Industries, Inc. Unauthorized use not permitted.